

THIS DOCUMENT IS THE PROPERTY OF DME INC., AND CANNOT BE DISTRIBUTED WITHOUT DME'S AUTHORIZATION

REVISIONS				
ZONE	REV.	DESCRIPTION	DATE	APPROVED

BILL OF MATERIAL

ITEM	QTY	DESCRIPTION	MATERIAL
1	1	FIXED ASA FLANGE 150#	A 36
2	2	BRAID COLLAR,	A 240 T-304
3	1	STD. WT. L.R. 90° WELD ELBOW	A 234 GR.WPB
4A	1	METAL CONVOLUTED HOSE	A 240 T-321
4B	1	METAL BRAID	A 240 T-304
5	2	STD. WT. PIPE SPACER LIFTING LUG,	A 53-E GR.B C.S.

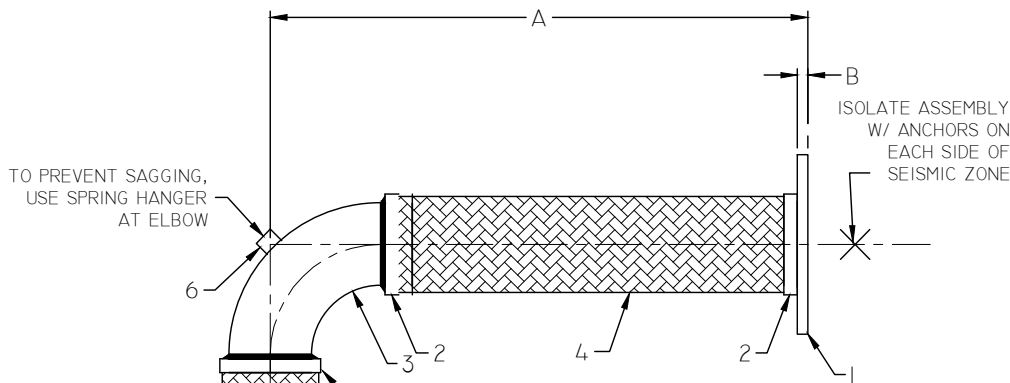

SEISMIC CONNECTOR
FOR ± 3" OF MOTION IN ANY PLANE.

GENERAL NOTES:

- A. ALL WELDING T.I.G. (HELI-ARC) IN ACCORDANCE WITH ASME SECTION IX.
- B. PRESSURE TEST ALL ASSEMBLIES AIR UNDER WATER AFTER FABRICATION, NO LEAKAGE.
- C. AFTER A SEISMIC OCCURENCE, THE SEISMIC EXPANSION JOINTS AND FLEX CONNECTORS MUST BE INSPECTED FOR DAMAGE AND REPLACED IF NECESSARY.
- D. SIZES 8" - 12" PROVIDED WITH LIFTING LUG.

SIZE	A	B	
2"	24.12"	0.63	DM7336-0200-3
2-1/2"	26.62"	0.63	DM7336-0250-3
3"	28.12"	0.63	DM7336-0300-3
4"	31.87"	0.63	DM7336-0400-3
5"	35.00"	0.75"	DM7336-0500-3
6"	39.25"	0.75"	DM7336-0600-3
8"	50.00"	1-1/8"	DM7336-0800-3
10"	54.00"	1-1/8"	DM7336-1000-3
12"	58.00"	1-1/8"	DM7336-1200-3

APPROVED BY:.....

DATE:..... PO#:.....

ALL DIMENSIONS ARE IN INCHES



DME INC.
14001 MARQUARDT AVE.
SANTA FE SPRINGS, CA 90670
TEL: 562-921-0464
FAX: 562-802-7489

ANY CHANGES ON THE DRAWING MUST BE REPORTED AND APPROVED ONLY BY THE ENGINEERING DEPARTMENT

CUST: JOB#		DESIGN: PER CUST.	01-30-2013	SIZE	-
APPROVED BY: E.F.		01-30-2013	SCALE	NONE	
DWG: M.N.		01-30-2013			

EXPANSION JOINTS	
DWG NO. 0200-00000	REV.
DATE: 01-30-2013	SHT 1 OF 1

UNLESS OTHERWISE SPECIFIED TOLERANCES ARE :	
.XXX ± .010"	FRACTIONS: ± 1/8"
.XX ± .030"	EXP. JOINTS:
.X ± .060"	ANGLES ± 1/2°
	OAL: ± 1/8"